

INSTALLATION INSTRUCTIONS

Accessory
REMOTE CONTROL ENGINE STARTER

Application
2015 ILX

Publications No.
BII 51703
Issue Date
MAY 2014

PARTS LIST

Remote Engine Starter Unit Kit P/N 08E91-E54-200

Transmitter

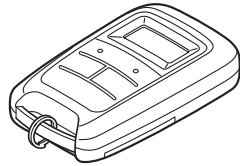

Control unit

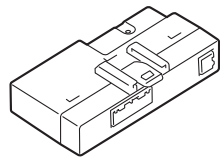

Antenna

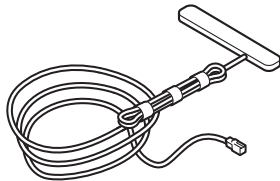

ID label



Remote Control Engine Starter Attachment Kit P/N 08E92-E54-200B

Engine starter harness

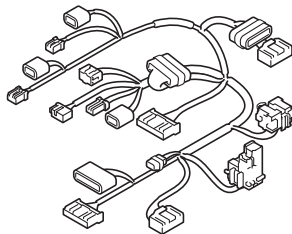

Control unit bracket

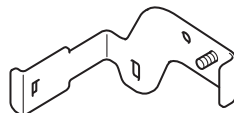

3 Relays

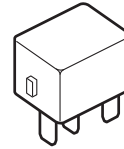

Flange nut



18 Wire ties

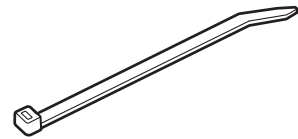

3 Long wire ties

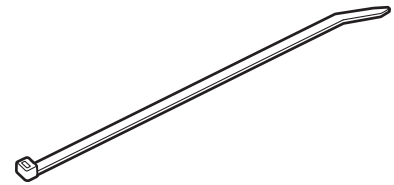

Wire tie with clip

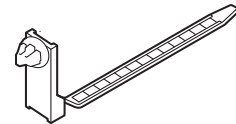

9 Urethane tapes

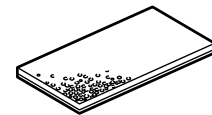

Clip

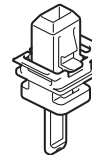

Caution label



Fuse label

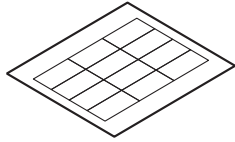

Accessory User's Information Manual

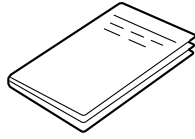

Quick Start Guide

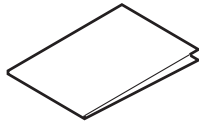

TOOLS AND SUPPLIES REQUIRED

Flat-tip screwdriver

Phillips screwdriver

Ratchet

10 mm Socket

Isopropyl alcohol

Shop towel

Tape measure

Scissors

HDS/MVCI

Masking tape

Diagonal cutters

Ruler

Electrical tape

The following tool is available through the Honda Tool and Equipment Program. On the iN, click on: Service > Service Bay > Tool and Equipment Program, then enter the number under "Search". Or, call 888-424-6857.

- Plastic Trim Tool (T/N SILTRIMTL10)

Illustration of the Remote Control Engine Starter on the Vehicle

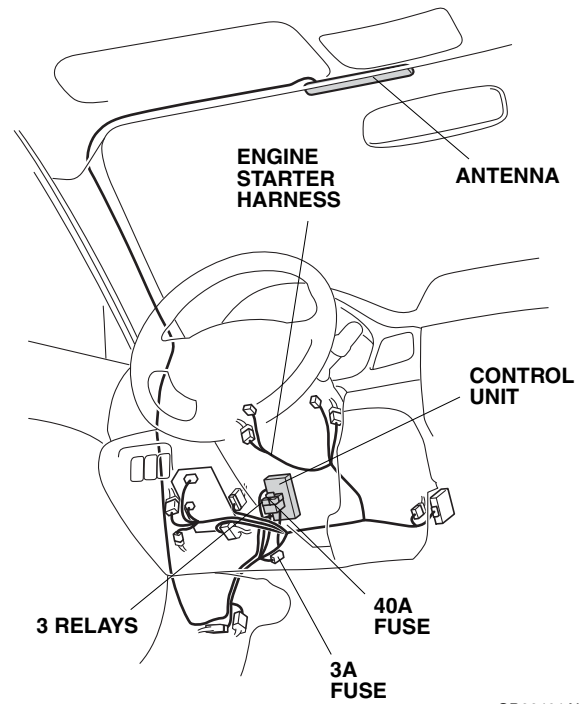

QB22401AH

INSTALLATION

Client Information: The information in this installation instruction is intended for use only by skilled technicians who have the proper tools, equipment, and training to correctly and safely add equipment to your vehicle. These procedures should not be attempted by "do-it-yourselfers."

1. Disconnect the negative cable from the battery.

- Using isopropyl alcohol on a shop towel, clean the area where the ID label will attach.

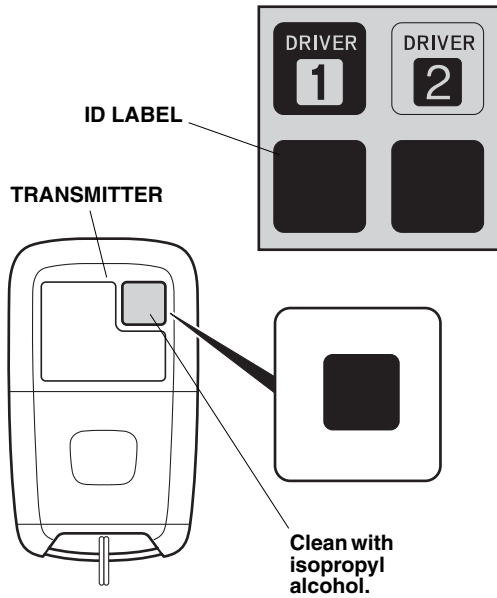

QB32111CH

- Attach the blank ID label to the transmitter in the area as shown.

- Using a plastic trim tool, remove the left and right lenses from the front roof module (two retaining tabs for each lens).

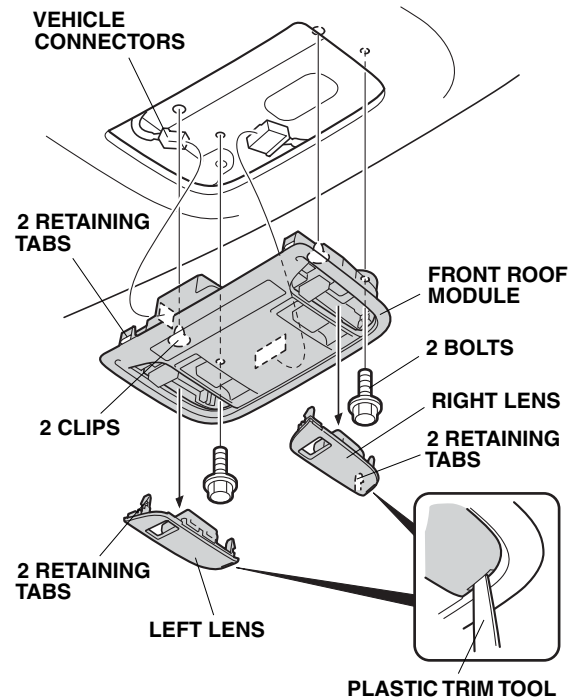

QA91802AH

- Remove the front roof module (two bolts, two clips, two retaining tabs, and unplug the vehicle connectors).
- Remove the driver's and passenger's sunvisor holders by turning them 45° in the counterclockwise direction.

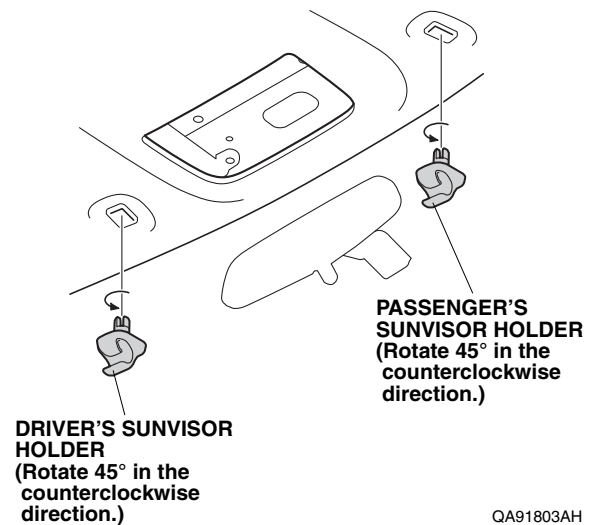

QA91803AH

7. Remove the driver's sunvisor:
 - Pivot the left sunvisor downward.
 - Wrap tape around the tip of flat-tip screwdriver.
 - Locate the slot in the bracket cover, and insert the flat-tip screwdriver into the slot. Push in and hold the retaining tab.
 - While holding the retaining tab, push up on the sunvisor and rotate it toward the door.

NOTE: If the retaining tab did not stay pushed in, return the sunvisor to its original position and repeat this step.

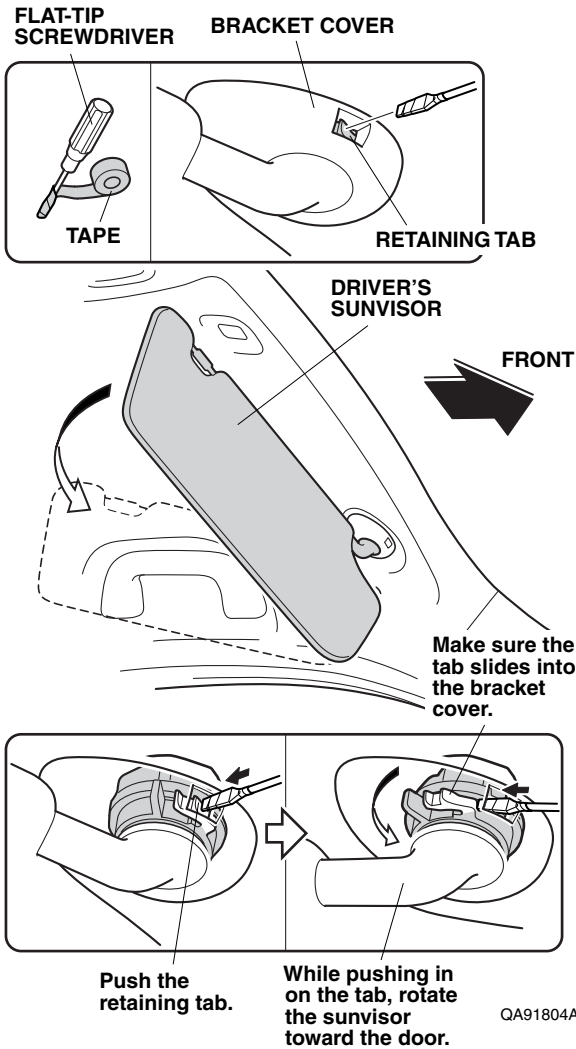

- Remove the driver's sunvisor (unplug the vehicle connector).

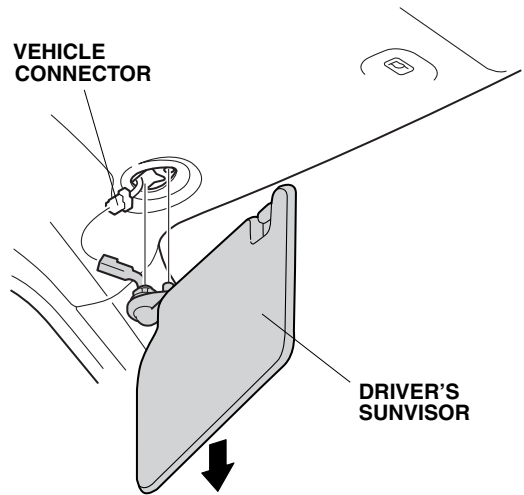

Q0D0431BH

8. Remove the driver's A-pillar trim.
 - Pull away the driver's door opening seal from the driver's A-pillar trim.
 - Pull out on the driver's A-pillar trim to release three clips.

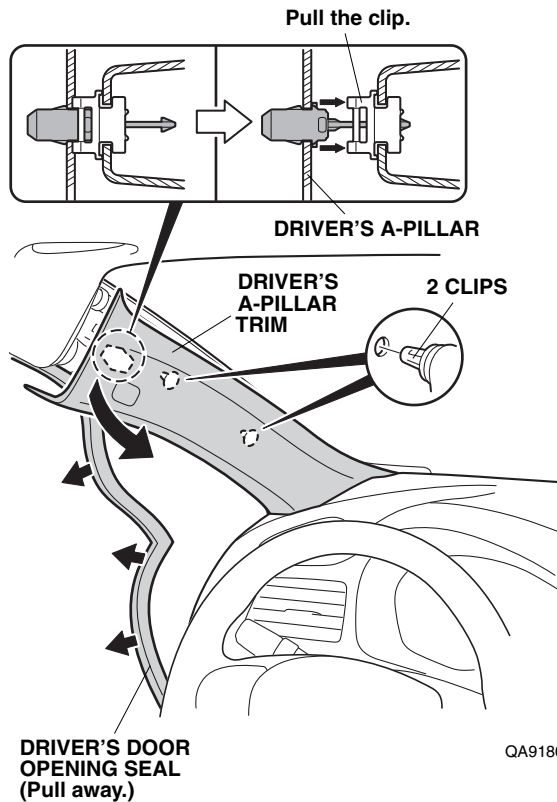

- To prevent clips from falling into the body panel area, carefully insert a shop towel between the driver's A-pillar and the driver's A-pillar trim.

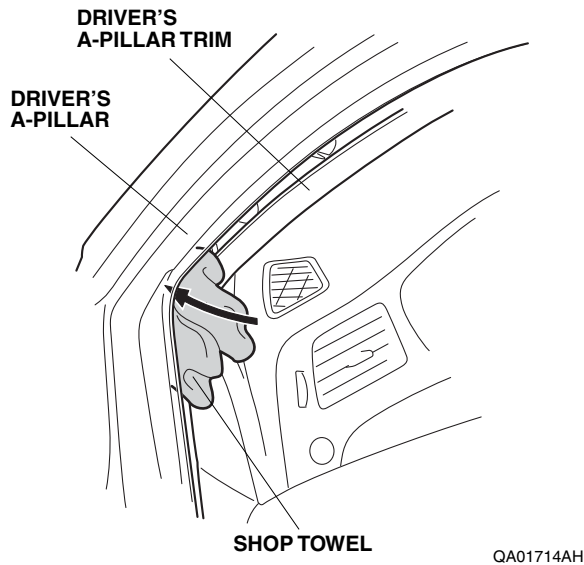

- Slide the driver's A-pillar trim upward, and remove the driver's A-pillar trim.
- Remove the shop towel and any clips.

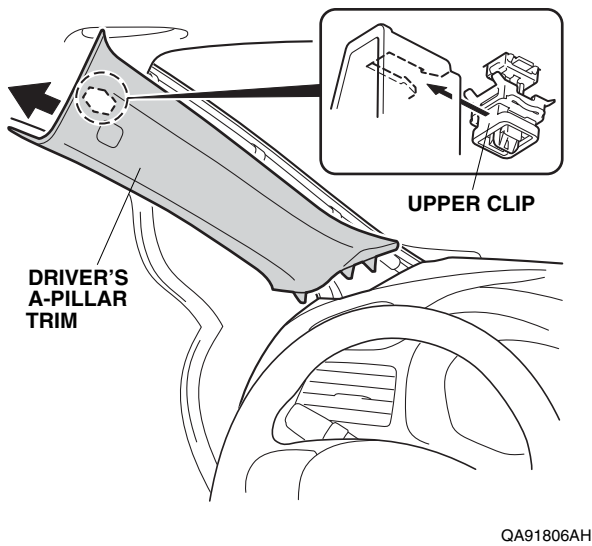

- Remove the remaining upper clip from the driver's A-pillar.

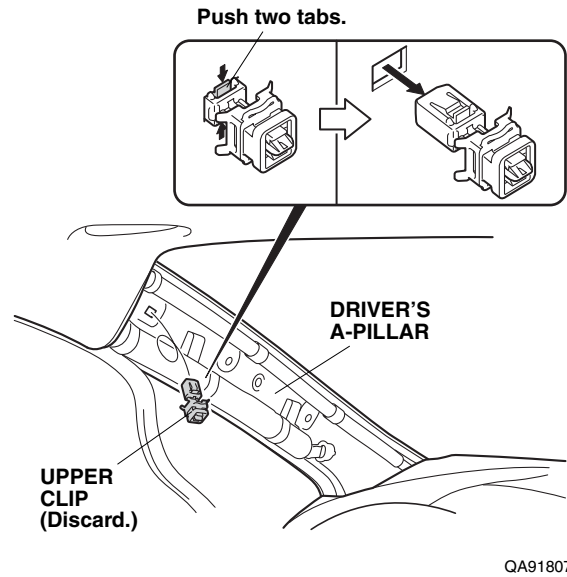

- Install the new clip (supplied) to the driver's A-pillar trim.
NOTE: When reinstalling the A-pillar trim, refer to the service manual for the correct overlap procedure.

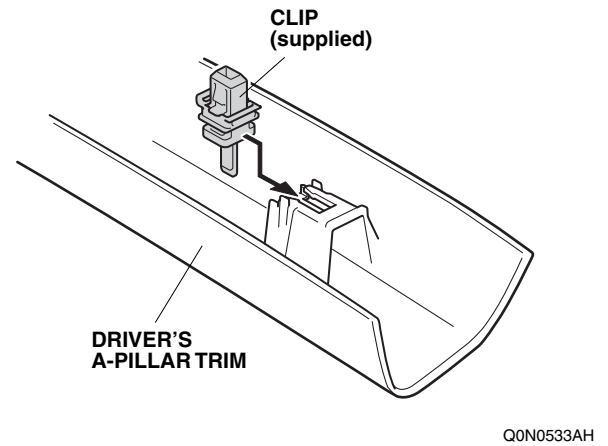

- Remove the driver's dashboard lower cover (nine clips, and unplug the vehicle connector).

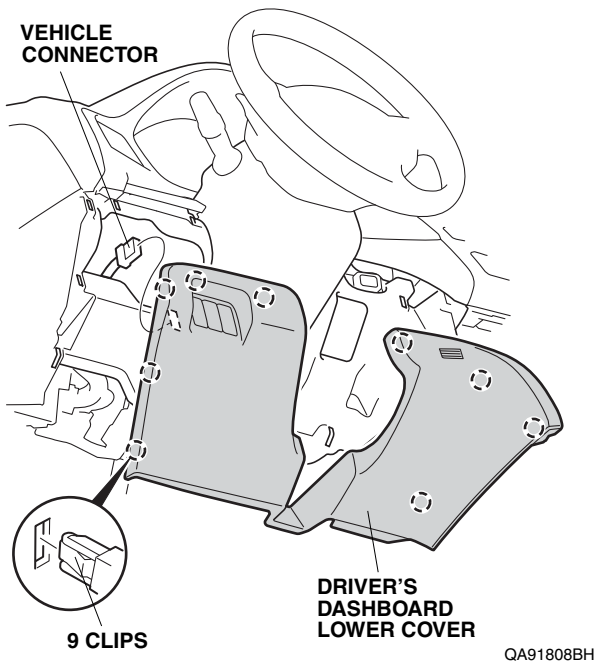

- Remove the trunk lid/fuel fill door opener cover (four retaining tabs and two hooks). Remove one self-tapping screw. Using the key, unlock the trunk lock.

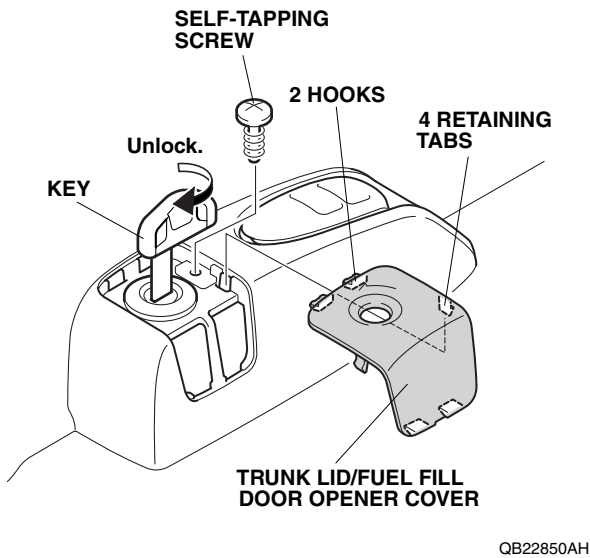

- Remove the driver's front door sill trim (six clips, two hooks, and four retaining tabs).

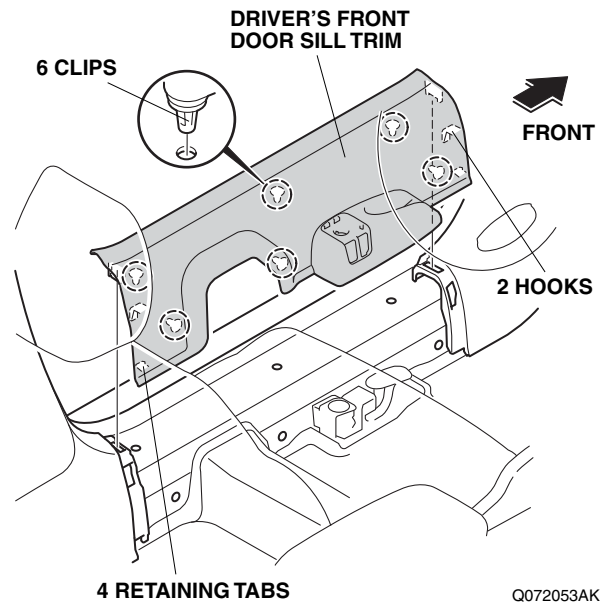

- Pull away the door opening seal, and remove the driver's kick panel (two clips).

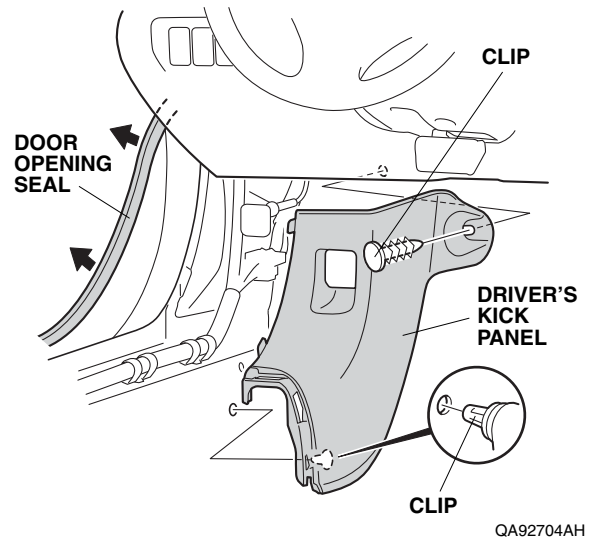

15. Reconnect the negative cable to the battery. Press the engine start/stop button to select the ON mode. Lower the tilt lever. Pull and lower the steering wheel.

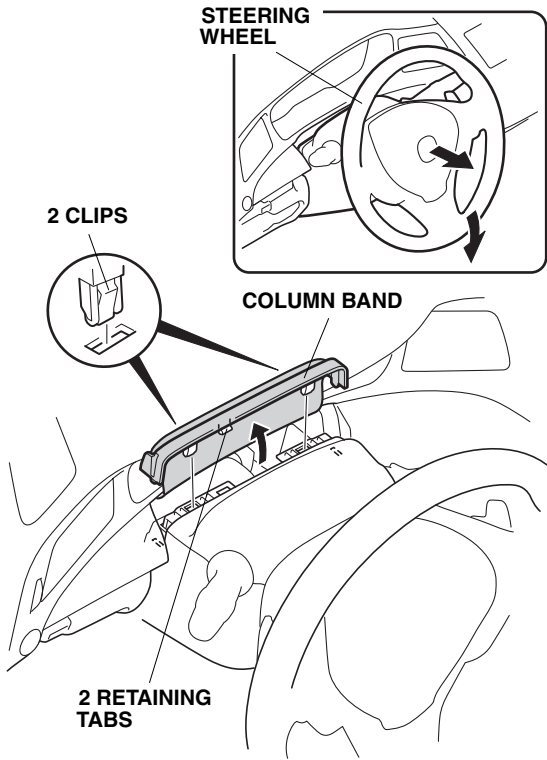

QA00402AH

16. Release the column band (two clips and two retaining tabs).

17. Turn the steering wheel 90° counterclockwise. Using a plastic trim tool, release the retaining tab.

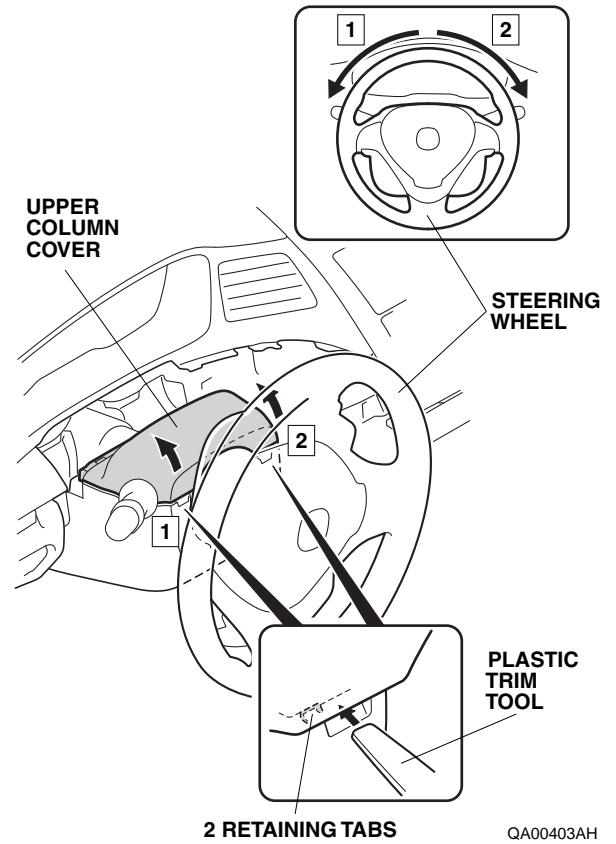

QA00403AH

18. Turn the steering wheel 180° clockwise. Using a plastic trim tool, release the retaining tab.
19. Remove the upper column cover (two retaining tabs and two hooks).

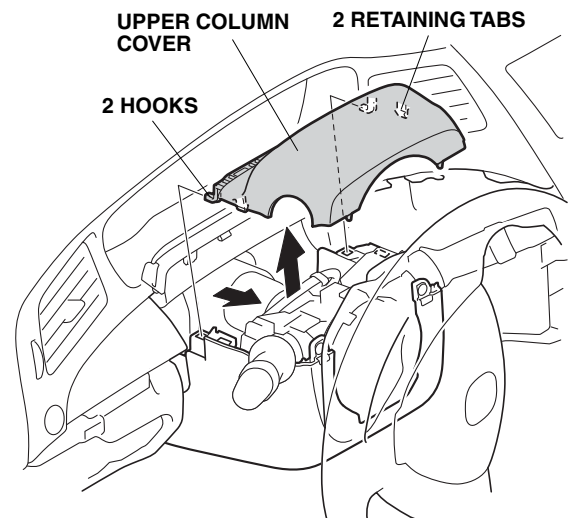

QA00404AH

- Remove one self-tapping screw from the lower column cover.

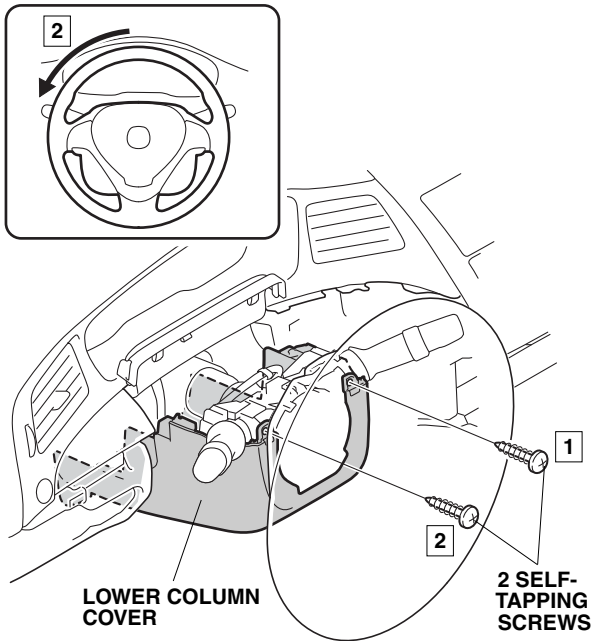

QA00405BH

- Turn the steering wheel 180° counterclockwise. Remove one self-tapping screw from the lower column cover.
- Remove the lower column cover (one self-tapping screw).

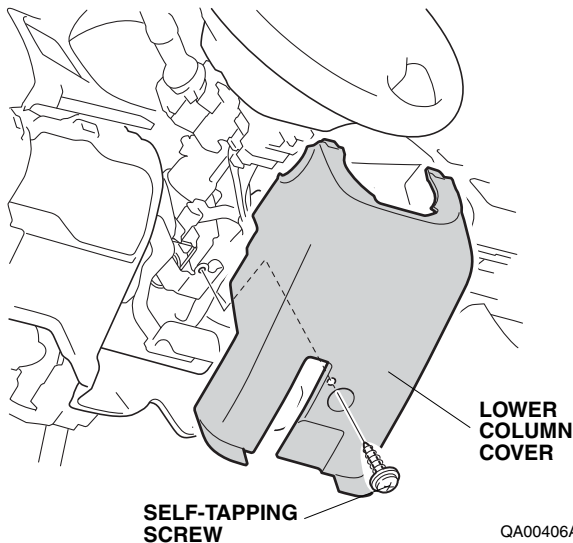

QA00406AH

- Press the engine start/stop button to select the OFF mode. Disconnect the negative cable from the battery.

Installing the Antenna

- Using scissors, cut one urethane tape in half. Wrap two halves of urethane tape to the antenna cable as shown.

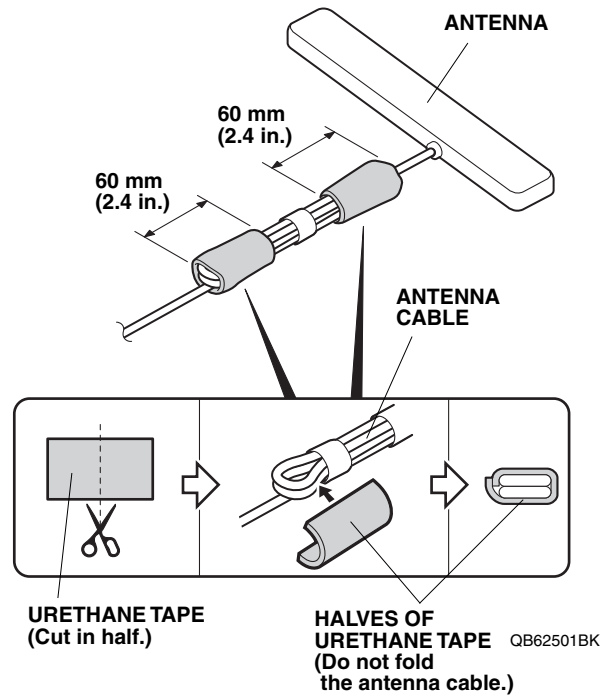

25. Starting near the antenna end of the cable, wrap two urethane tapes around the antenna cable at the measurements shown.

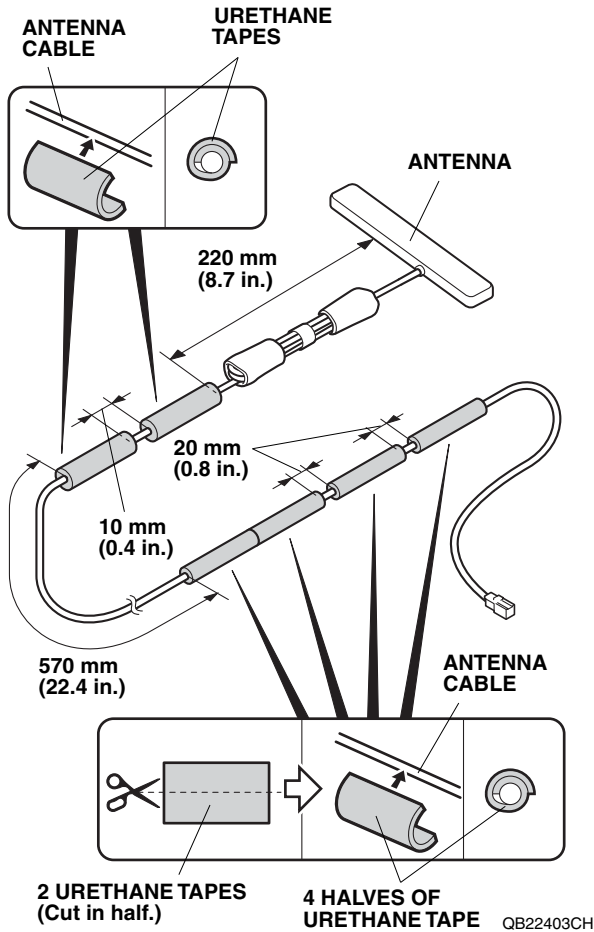

26. Using scissors, cut two urethane tapes in half. Wrap four halves of urethane tape around the antenna cable at the measurements shown.

27. Attach the antenna.

- Attach masking tape to the windshield at the measurement shown.

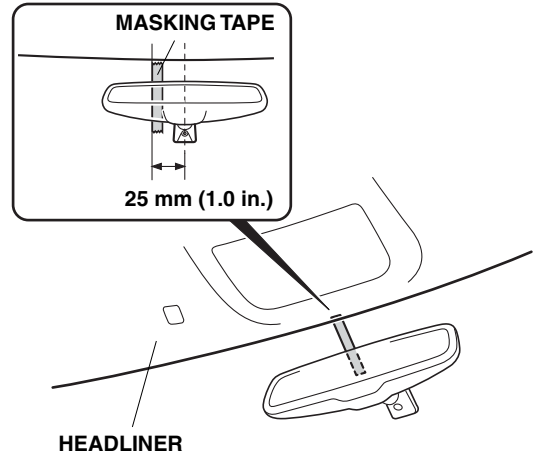

QB22404CH

- Fold the adhesive backing of the antenna as shown.

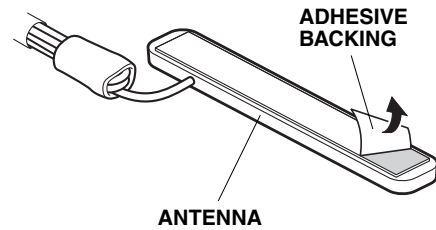

QB51401CH

- Using isopropyl alcohol on a shop towel, clean the windshield where the antenna will attach.
- Attach the antenna with masking tape. Adjust the position of the antenna so there is equal spacing on both sides.

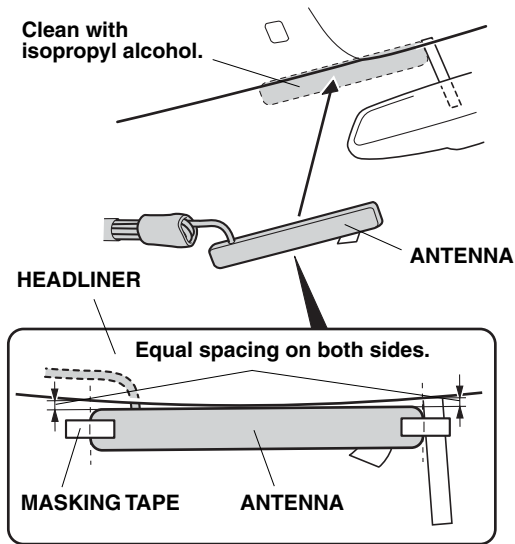

QB51404CH

- Carefully remove the adhesive backing from the antenna, and attach the antenna to the windshield. Press and hold the antenna firmly in place for 30 seconds.
- Remove the masking tape.

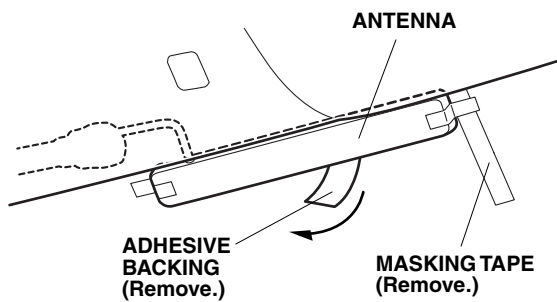

QB51405CH

28. Gently pull down the headliner, and tuck the antenna cable under the headliner. Be careful not to crease the headliner.

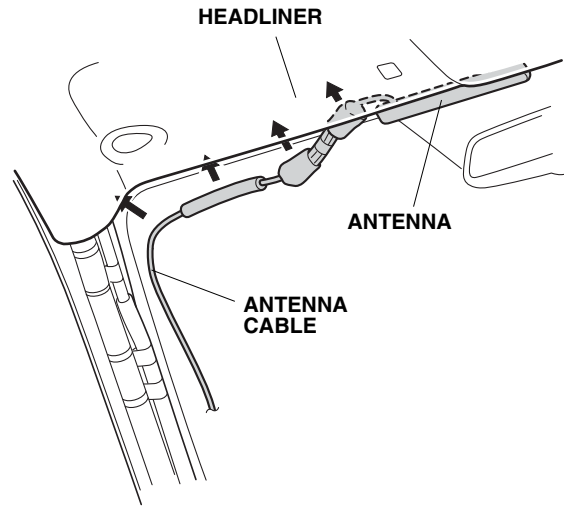

QB20904CH

29. Route the antenna cable down the A-pillar as shown. Using four wire ties, secure the antenna cable to the vehicle harness.

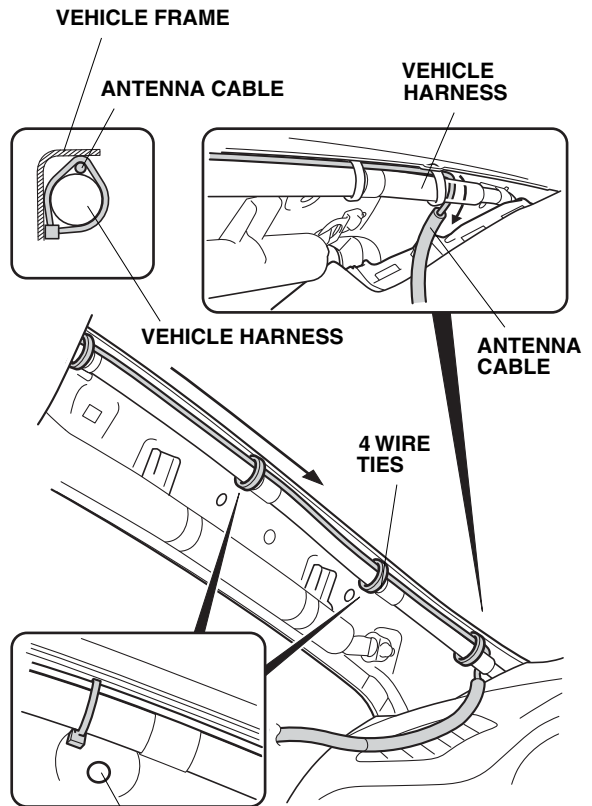

Be careful not to secure the wire ties over the holes.

QB22406AH

30. Using isopropyl alcohol on a shop towel, clean the vehicle panel where the urethane tape will attach.

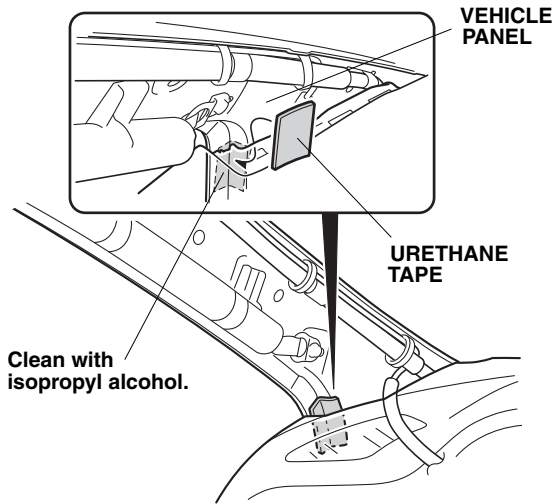

QB22407BH

31. Attach the urethane tape to the vehicle panel.
32. Pull away the door opening seal. Route the antenna cable down next to the dashboard, and tuck the antenna cable between the driver's A-pillar and the dashboard. Reinstall the door opening seal.

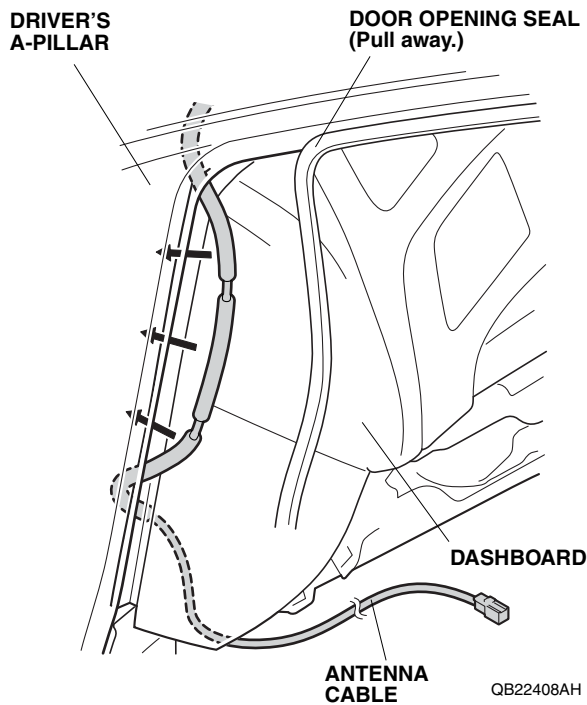

QB22408AH

Routing the Engine Starter Harness

33. Install three relays to the engine starter harness relay blocks.

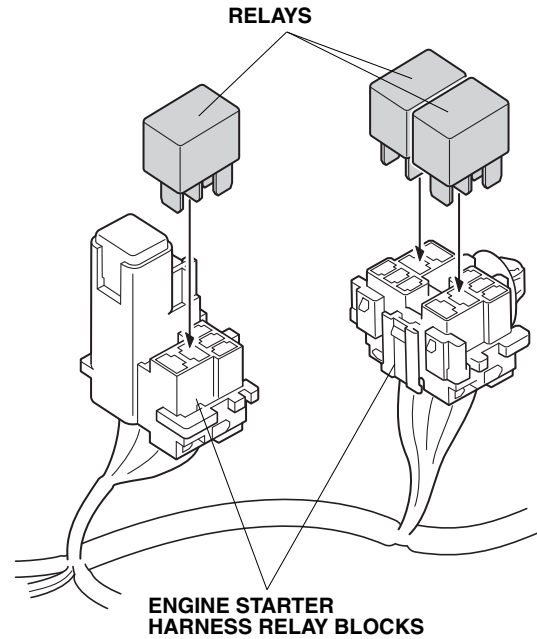

QB22409AH

34. Using isopropyl alcohol on a shop towel, clean the area where the fuse label will attach.

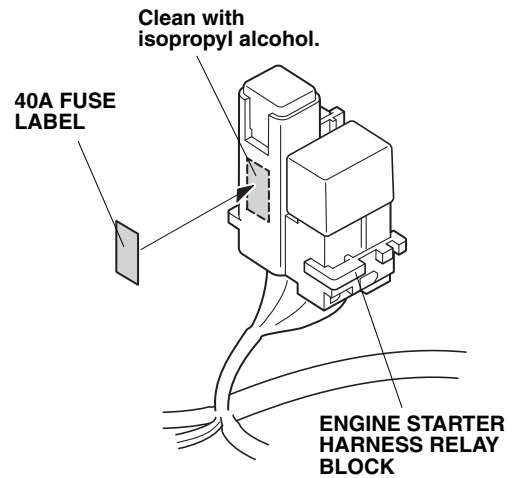

QB22410AH

35. Attach the 40A fuse label to the engine starter harness relay block.

36. Using isopropyl alcohol on a shop towel, clean the area where the fuse label will attach.

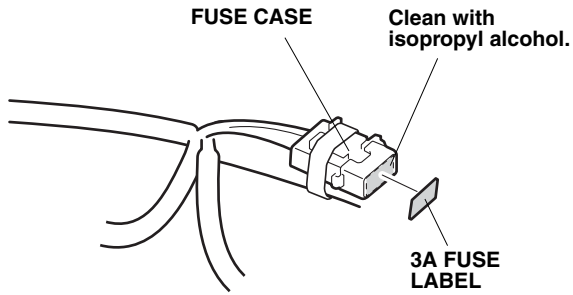

QB22411AH

37. Attach the 3A fuse label to the engine starter harness fuse case.
38. Plug the engine starter harness 28-pin connector into the control unit.

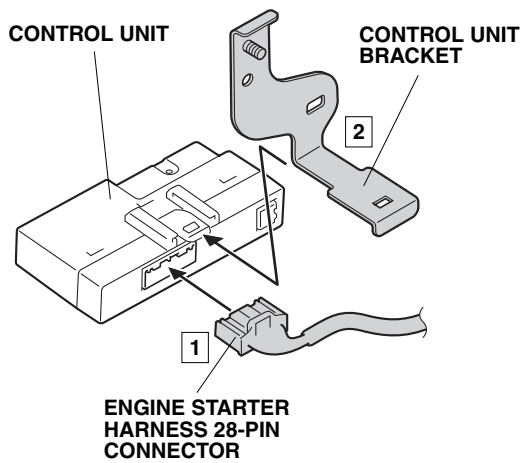

QB22412AH

39. Install the control unit bracket to the control unit.

40. Remove the data link connector (six retaining tabs).

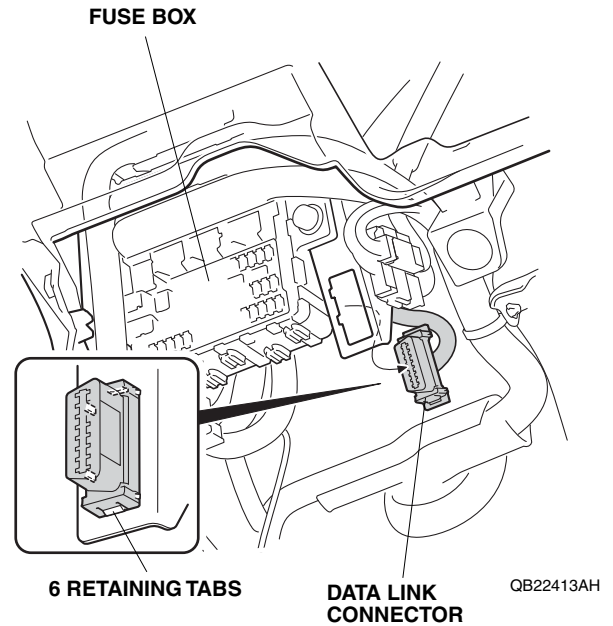

QB22413AH

41. Unplug the vehicle connectors.

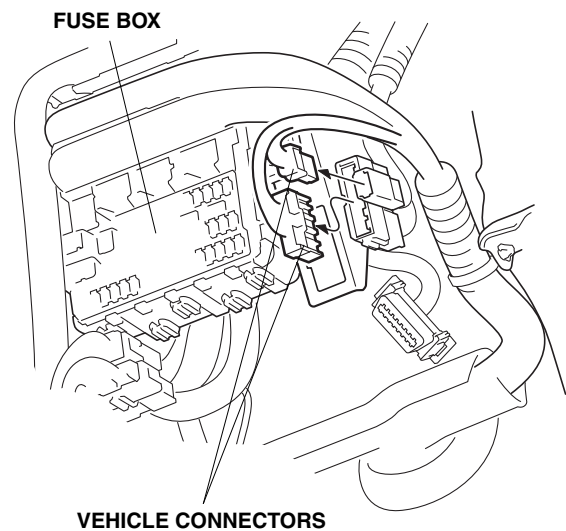

QB22414AH

42. Remove the clip on the vehicle harness and vehicle connector from the vehicle frame.

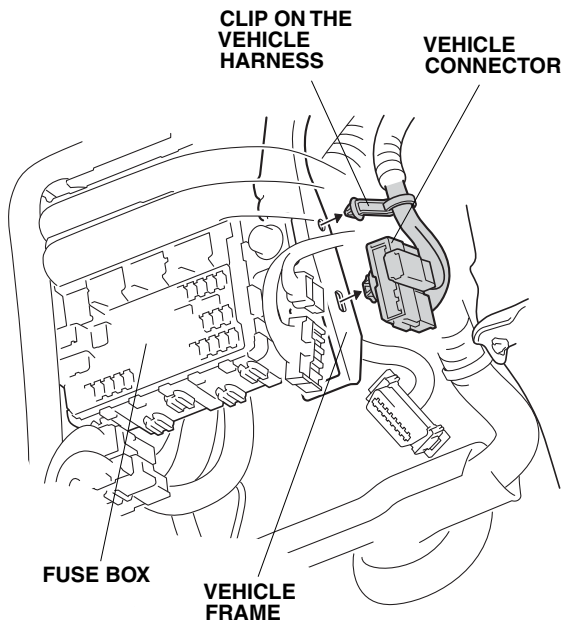

QB22415AH

43. Attach the wire tie with clip to the vehicle harness.

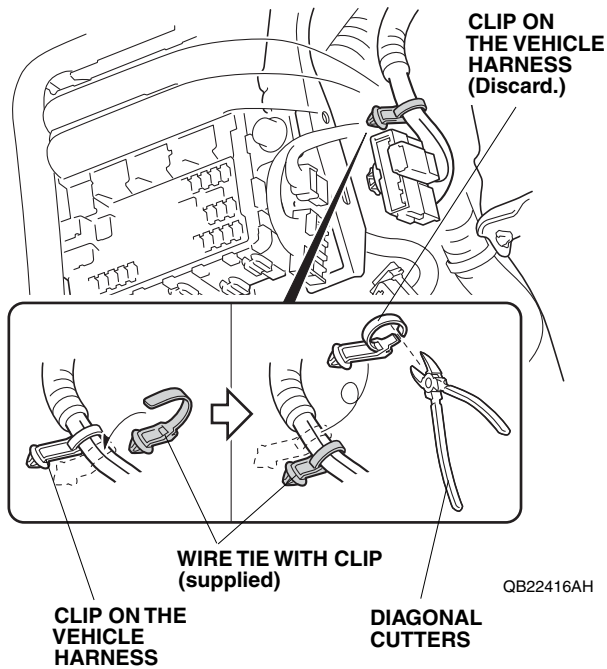

QB22416AH

44. Using a diagonal cutters, remove the clip from the vehicle harness. Do not damage the vehicle harness.

45. Using the flange nut, secure the control unit bracket to the vehicle frame.

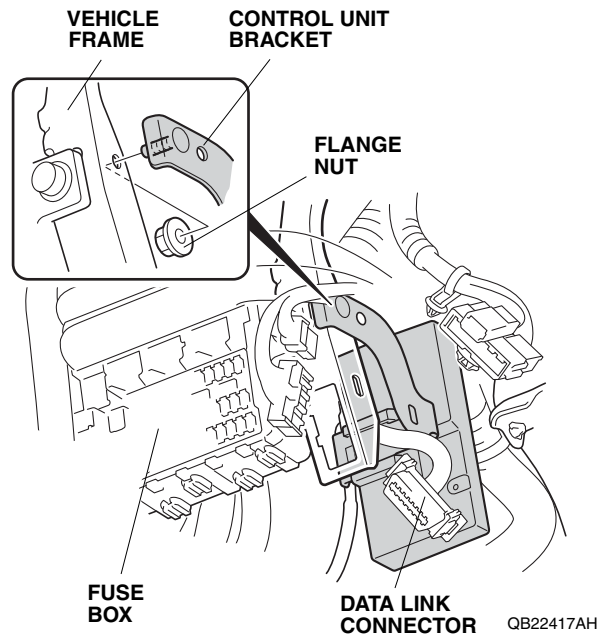

QB22417AH

46. Reinstall the data link connector.
47. Secure the wire tie with clip to the control unit bracket.

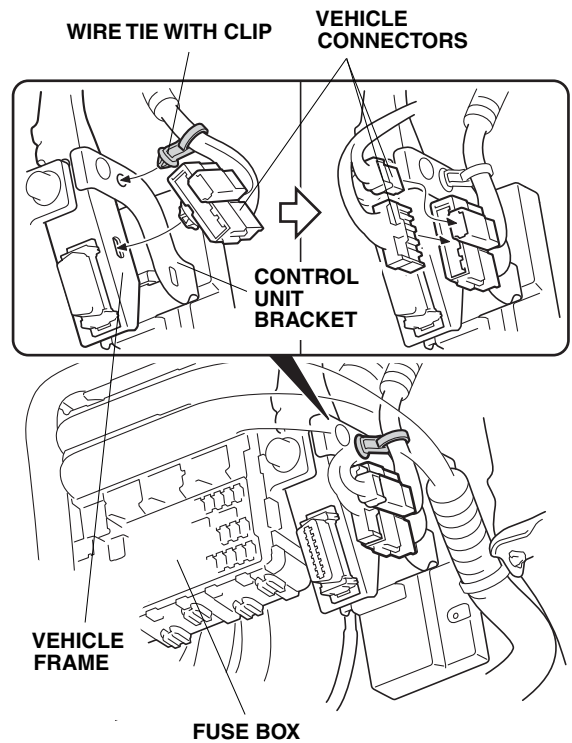

QB22418AH

48. Attach the vehicle connector to the vehicle frame, and reconnect the vehicle connectors.

49. Attach the engine starter harness relay block as shown.

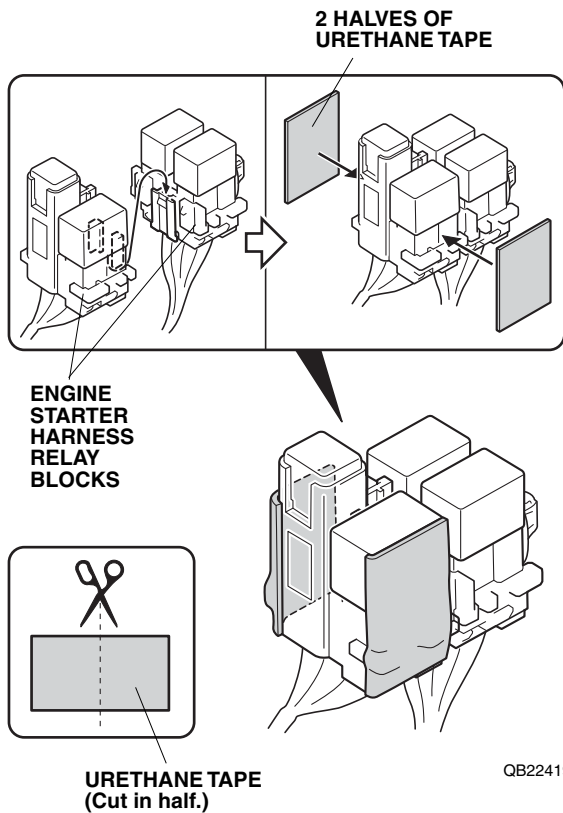

50. Using scissors, cut one urethane tape in half. Attach two halves of urethane tape to the engine starter harness relay block.
51. Attach the engine starter harness relay blocks to the control unit bracket.

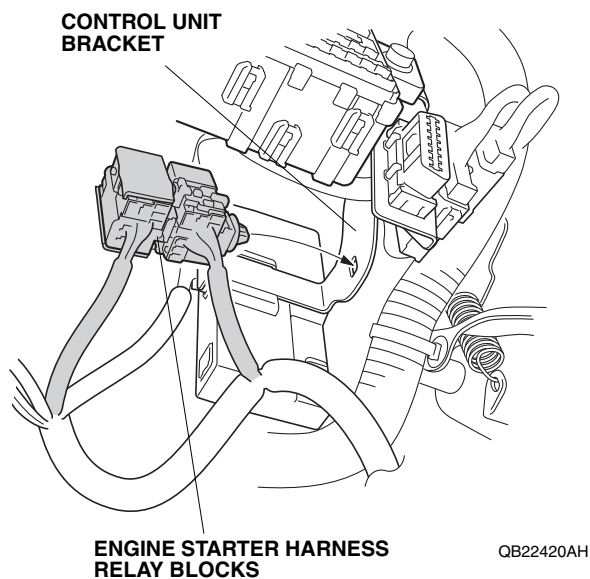

52. Align the white tape on the engine starter harness with the clip on the vehicle harness, and secure the engine starter harness to the vehicle harness using one wire tie.

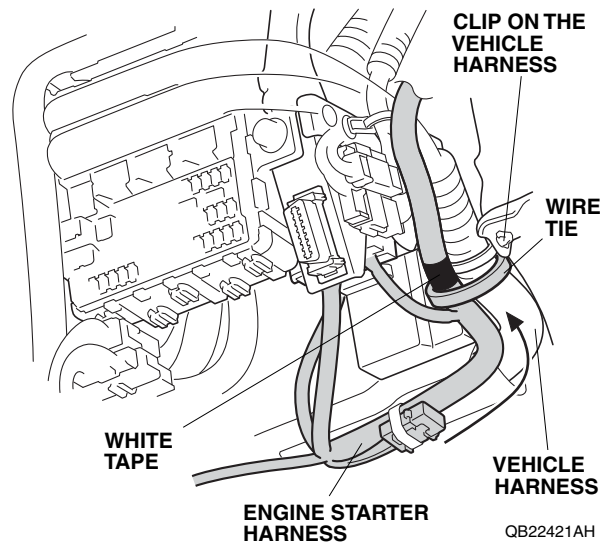

53. Unplug the vehicle 20-pin connector, and plug it into the engine starter harness 20-pin connector. Plug the engine starter harness 20-pin connector into the vehicle 20-pin connector.

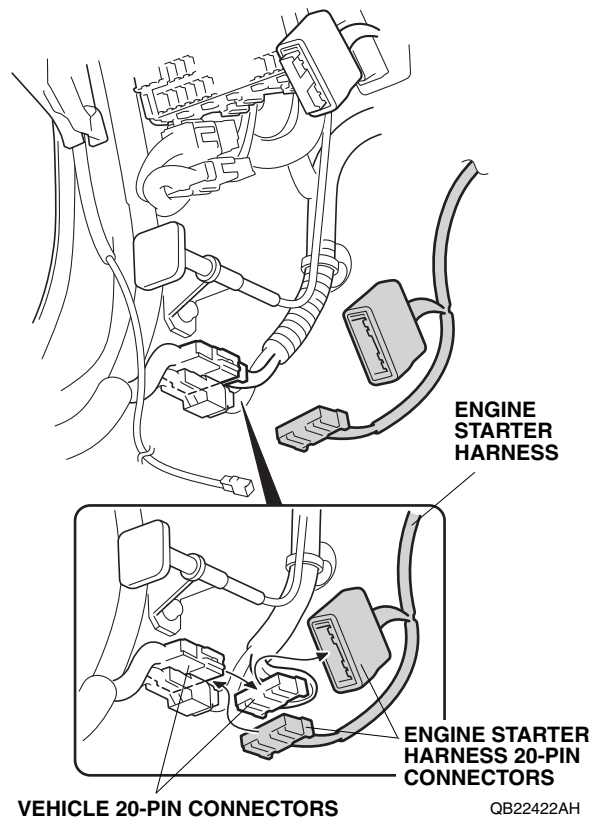

54. Route the antenna cable as shown. Using one wire tie, secure the antenna cable to the vehicle harness.

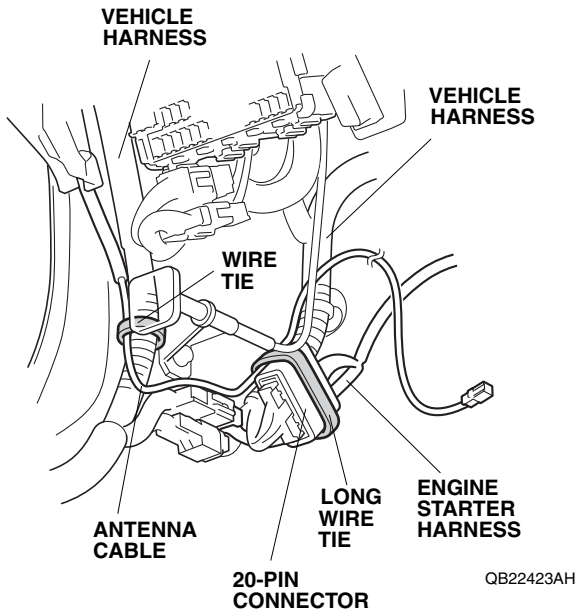

55. Using one long wire tie, secure the antenna cable and engine starter harness 20-pin connector to the vehicle harness.
56. Plug the antenna cable connector into the control unit as shown.

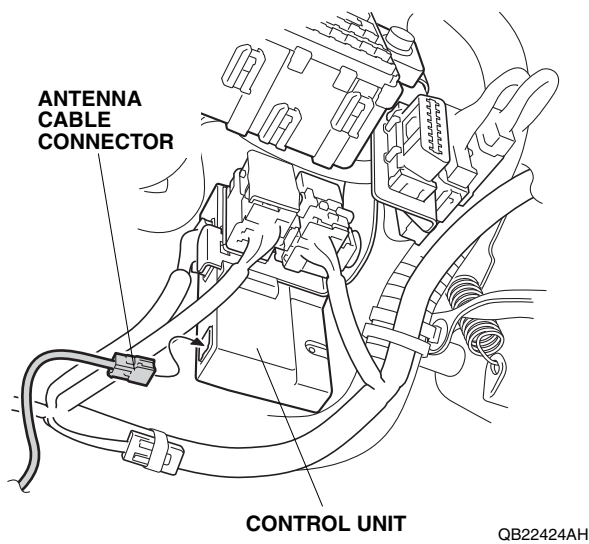

57. Using one wire tie, secure the antenna cable and engine starter harness to the vehicle harness.

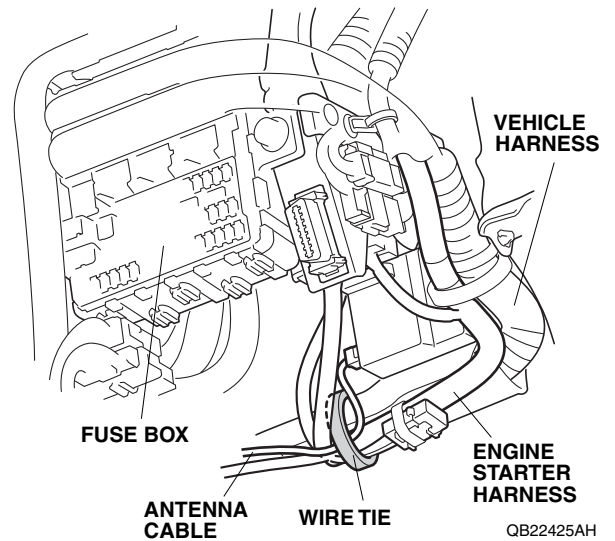

58. Bundle up the excess antenna cable as shown.

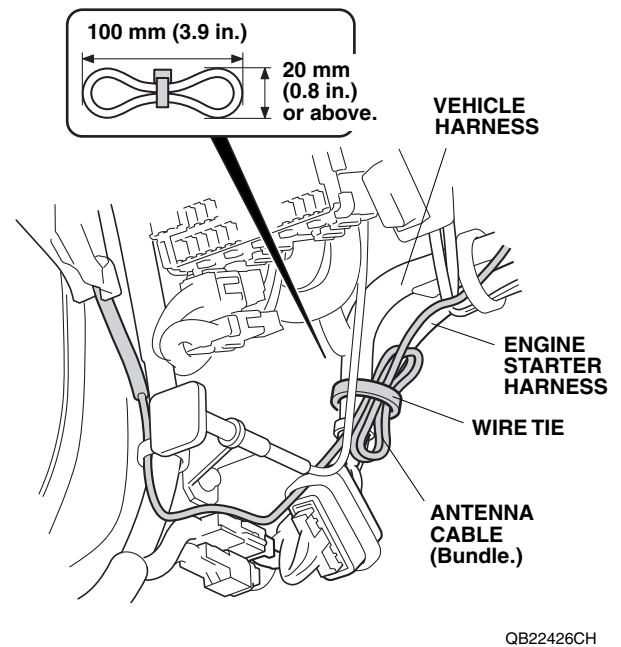

59. Using one wire tie, secure the antenna cable and engine starter harness to the vehicle harness.

60. Using one wire tie, secure the engine starter harness to the vehicle harness.

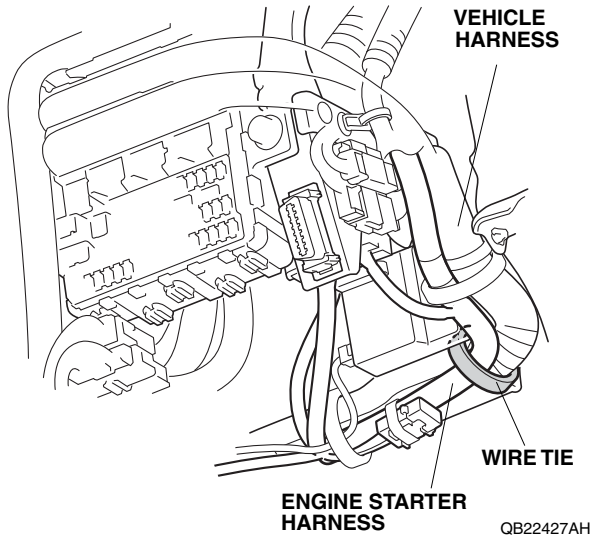

61. Unplug the vehicle 28-pin connector, and plug it into the engine starter harness 28-pin connector. Plug the engine starter harness 28-pin connector into the vehicle 28-pin connector.

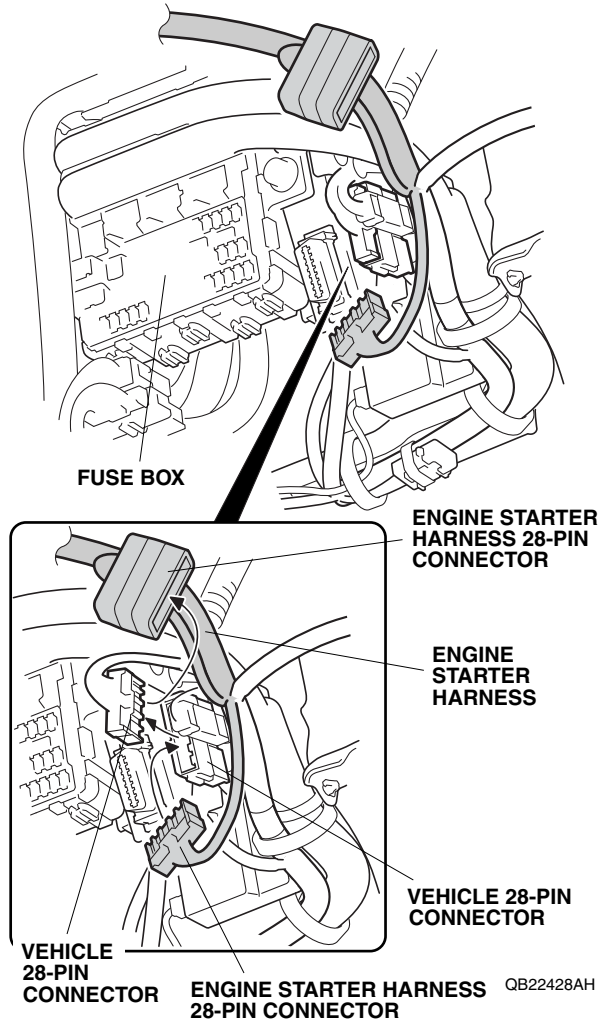

62. Plug the engine starter harness 4-pin connector into the fuse box.

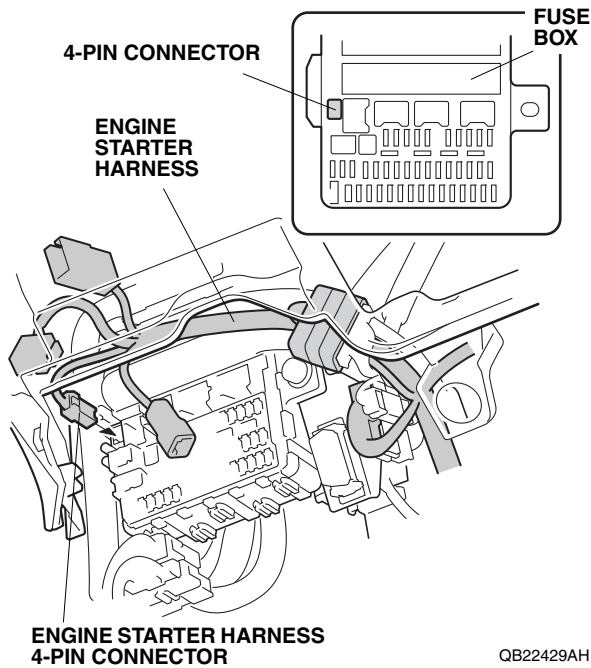

NOTE: If another accessory 4-pin connector is plugged into the fuse box, unplug the 4-pin connector from the fuse box, then plug the engine starter harness 4-pin connector into the fuse box. Plug another accessory 4-pin connector into the engine starter harness 4-pin connector.

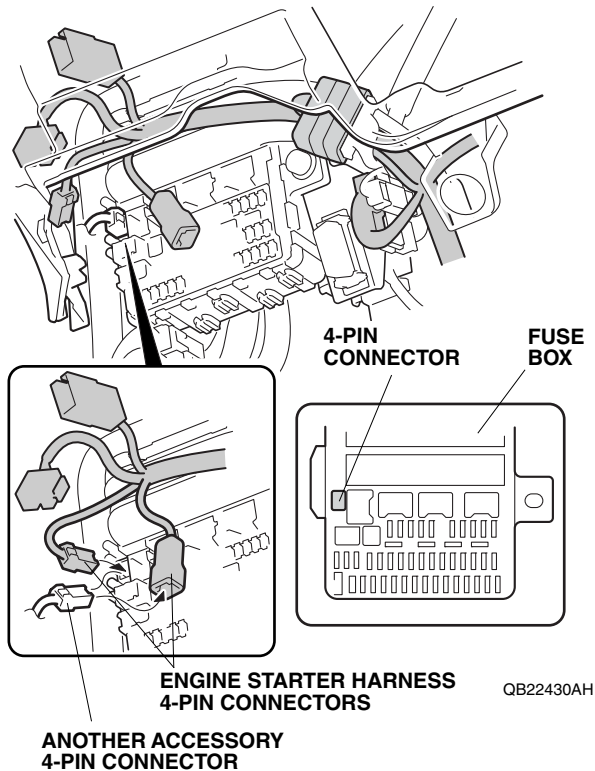

63. Using one wire tie, secure the engine starter harness 4-pin connector to the vehicle harness.

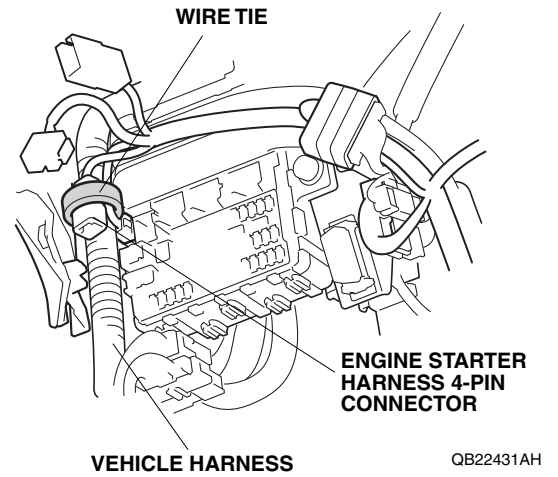

64. Using one long wire tie, secure the engine starter harness to the vehicle harness.

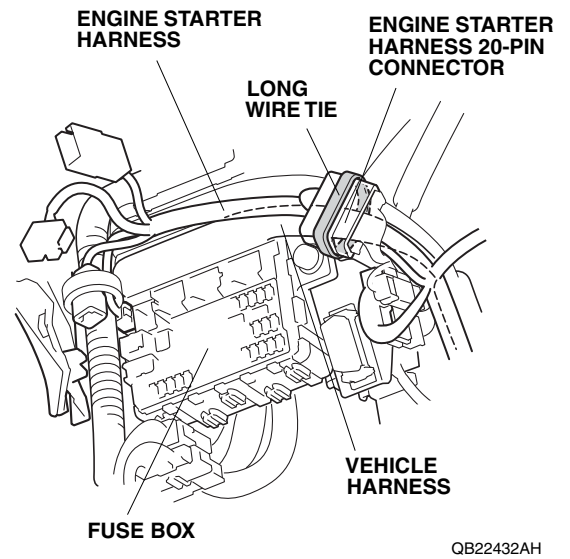

65. Using scissors, cut one urethane tape to the measurements shown. Wrap the cut urethane tape around the engine starter harness 5-pin connector.

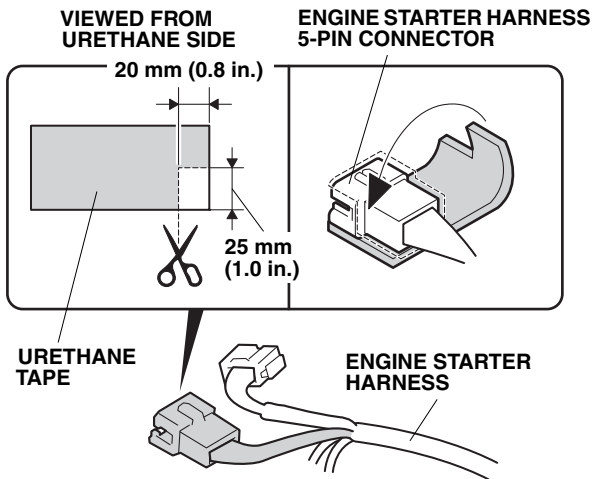

QB22433AH

66. Unplug the vehicle 5-pin connector from the fuse box. Plug the engine starter harness 5-pin connector into the fuse box 5-pin connector. Plug the vehicle 5-pin connector into the engine starter harness 5-pin connector.

NOTE: Make sure the engine starter harness 5-pin connector is securely connected. A loose connection can cause the engine to stall.

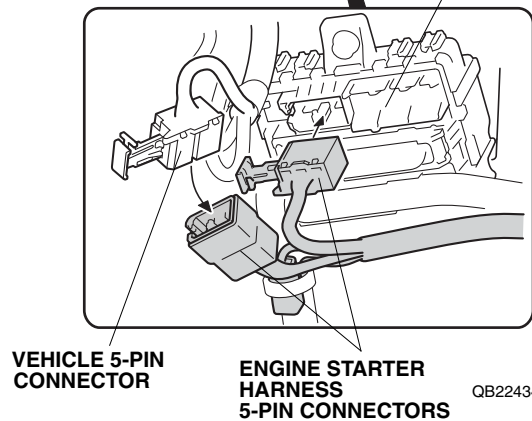
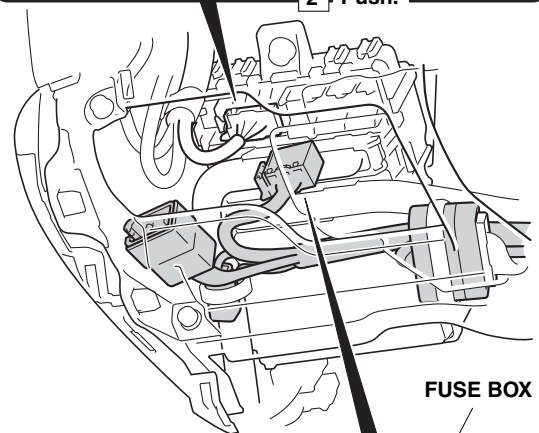
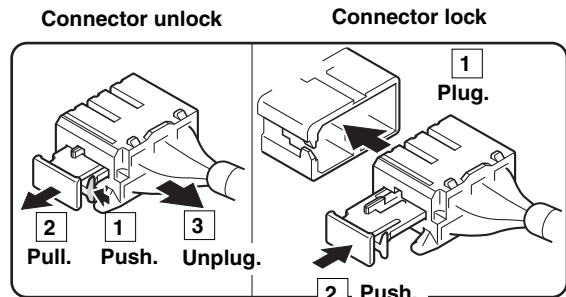

QB22434AH

67. Using one long wire tie, secure the engine starter harness 5-pin connector to the vehicle panel.

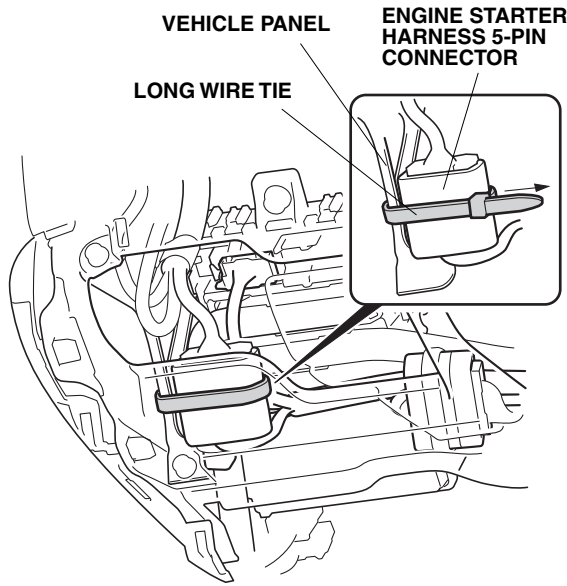

QB22435AH

68. Route the engine starter harness as shown. Using two wire ties, secure the engine starter harness to the holes in the dashboard panel.

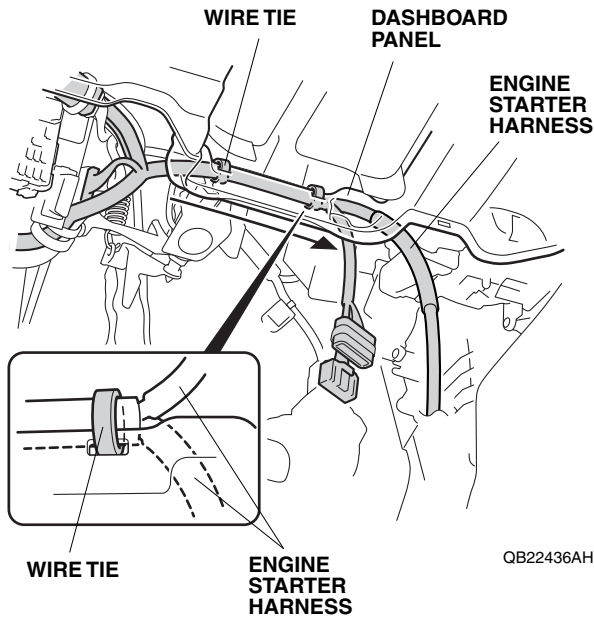

QB22436AH

69. Unplug the vehicle 32-pin connector from the vehicle control unit, and plug it into the engine starter harness 32-pin connector. Plug the engine starter harness 32-pin connector into the vehicle control unit.

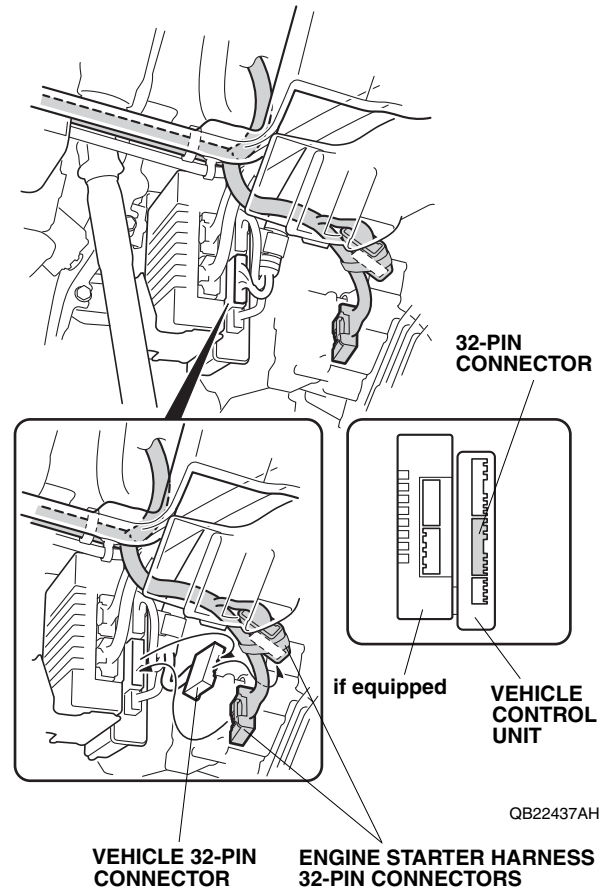

QB22437AH

70. Align the white tape on the engine starter harness with the clip on the vehicle harness, and secure the engine starter harness to the vehicle harness using one wire tie.

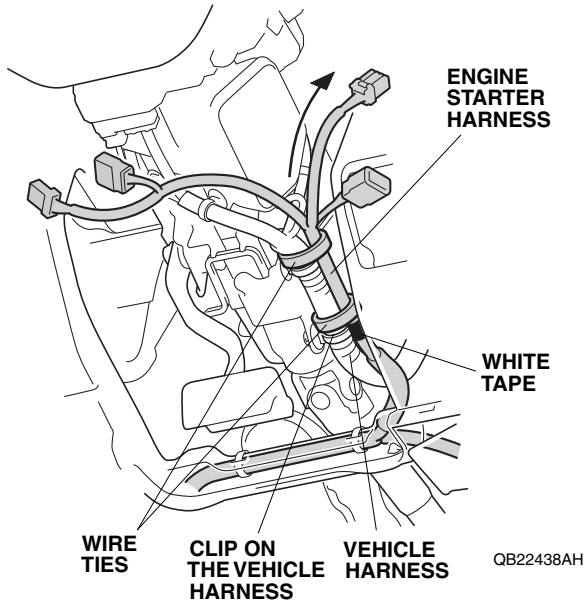

71. Using one wire tie, secure the engine starter harness to the vehicle harness.

72. Unplug the vehicle 10-pin connector, and plug it into the engine starter harness 10-pin connector. Plug the remaining engine starter harness 10-pin connector into the wiper switch.

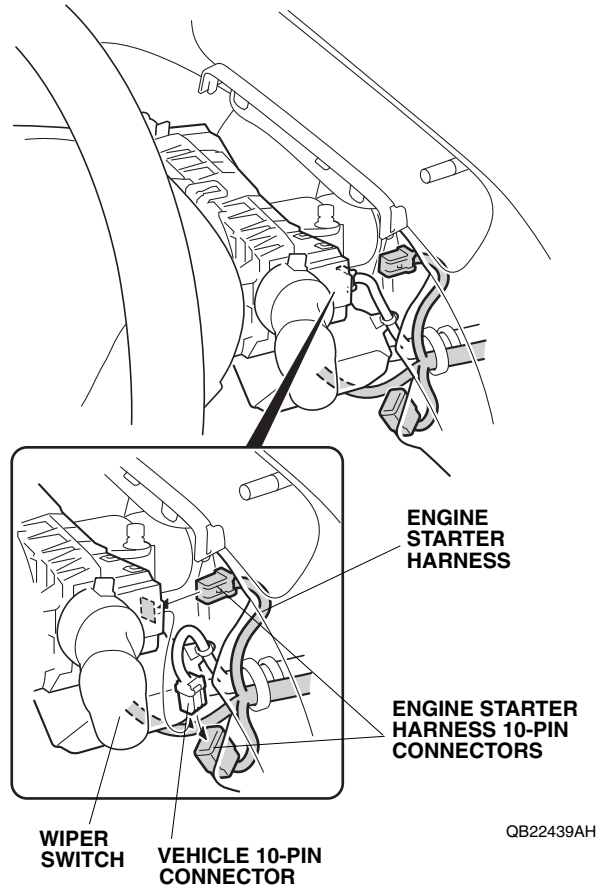

73. Using one wire tie, secure the engine starter harness 10-pin connector to the vehicle harness.

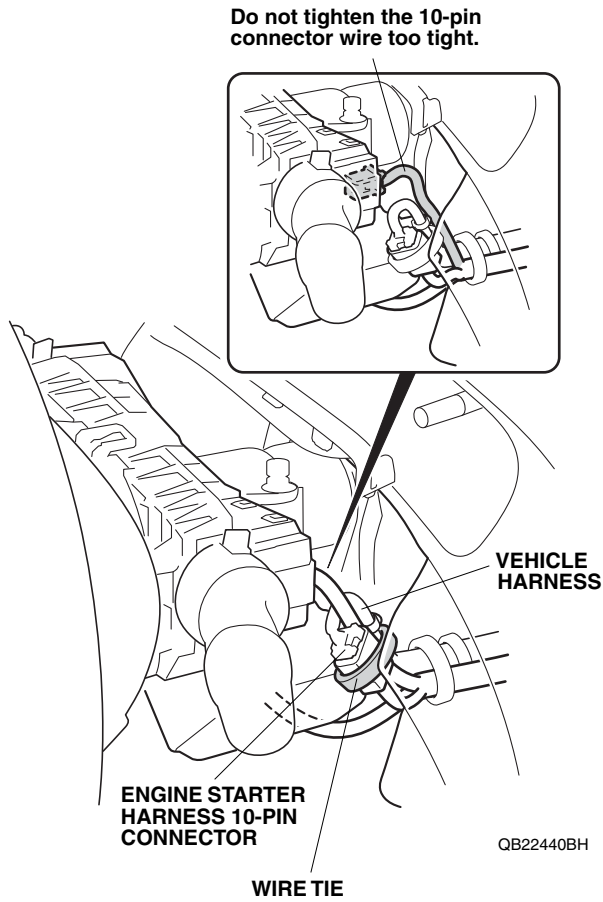

74. Unplug the vehicle 12-pin connector, and plug it into the engine starter harness 12-pin connector. Plug the remaining engine starter harness 12-pin connector into the combination light switch.

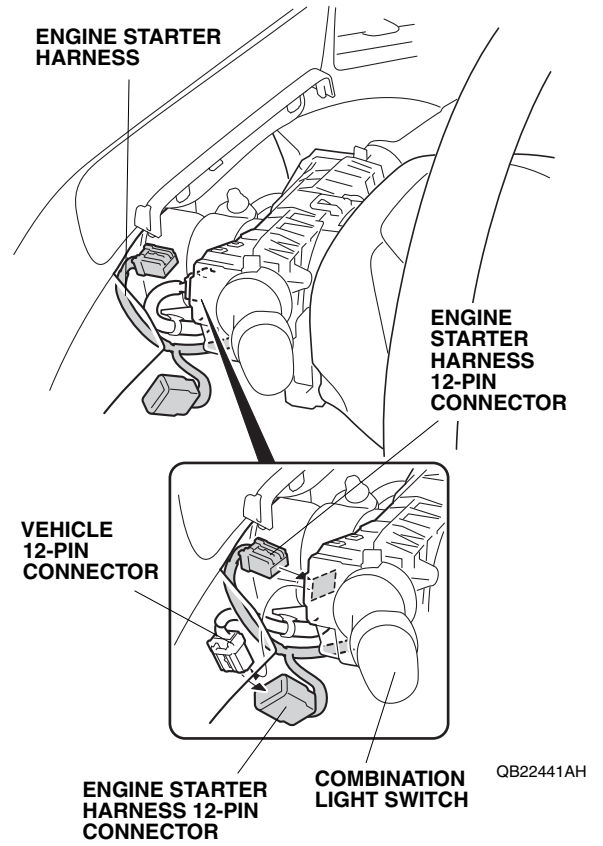

75. Using one wire tie, secure the engine starter harness 12-pin connector to the vehicle harness.

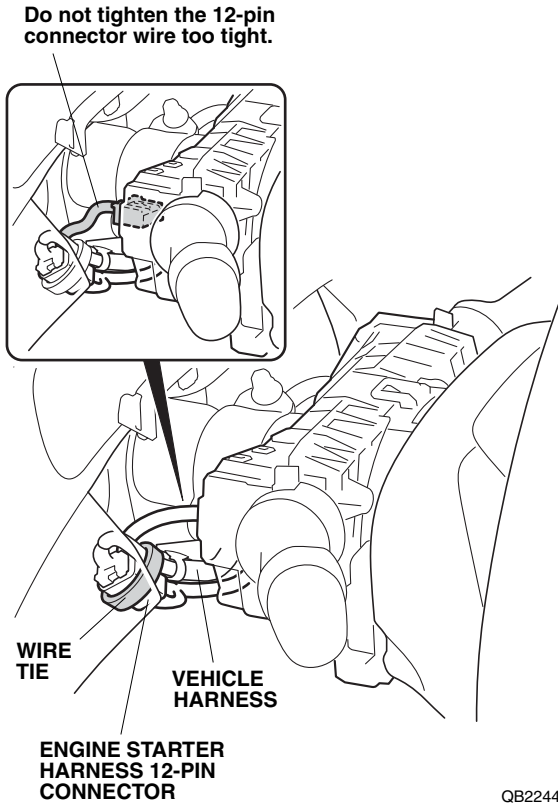

76. Using two wire ties, secure the engine starter harness to the vehicle harness.
NOTE: Make sure that the connectors and harness are not pinched, or are not interfering with the steering wheel when it is moved for adjustment.

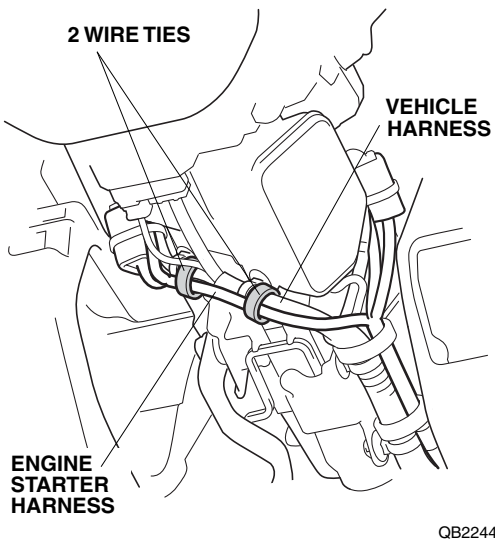

77. Using isopropyl alcohol on a shop towel, clean the area where the urethane tape will attach.

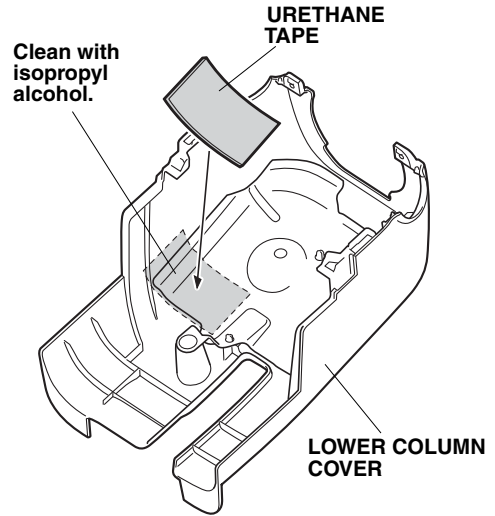

78. Attach one urethane tape to the lower column cover.
79. Using isopropyl alcohol on a shop towel, clean the hood where the caution label will attach.

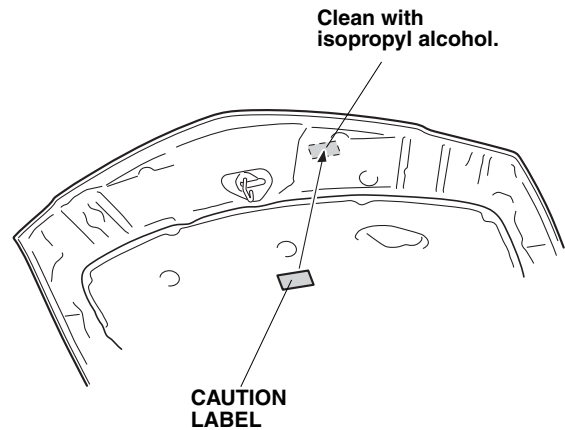

80. Attach the caution label to the hood in the area shown.

81. Check that all wire harnesses are routed properly and all connectors are plugged in.
82. Check the overlap between the headliner and the driver's A-pillar trim. Refer to the service manual. If necessary, adjust the overlap.
83. Reinstall all removed parts.
84. Reconnect the negative cable to the battery.
85. Press and hold the radio power button for two seconds to restore the radio and navi (if equipped) system functions.
86. Reset the clock.
87. Perform the "REMOTE ENGINE STARTER REGISTRATION" and the "FUNCTION CHECK".

REMOTE ENGINE STARTER REGISTRATION

1. Acquire the PCM Code from the Interactive Network.

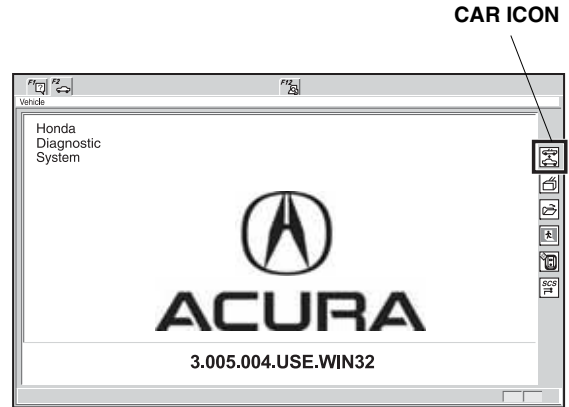

QB70450AH

2. Connect the HDS/MVCI tester to the OBD II data link connector, then turn the ignition switch to the on (II) position.
3. Start the HDS, and click the car icon.
4. Input the VIN and other required information into the HDS, then click the check button.

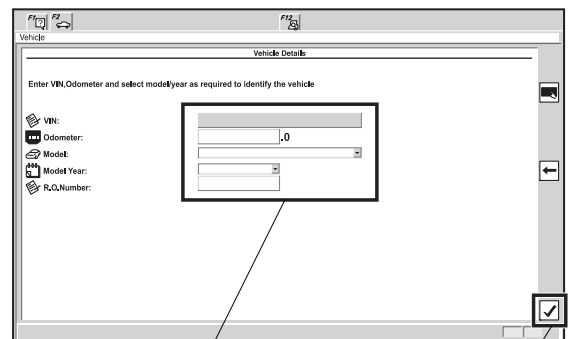

Input the VIN and other required information.

CHECK BUTTON

QB32102BH

5. Select **Honda Systems**, then click the check button.

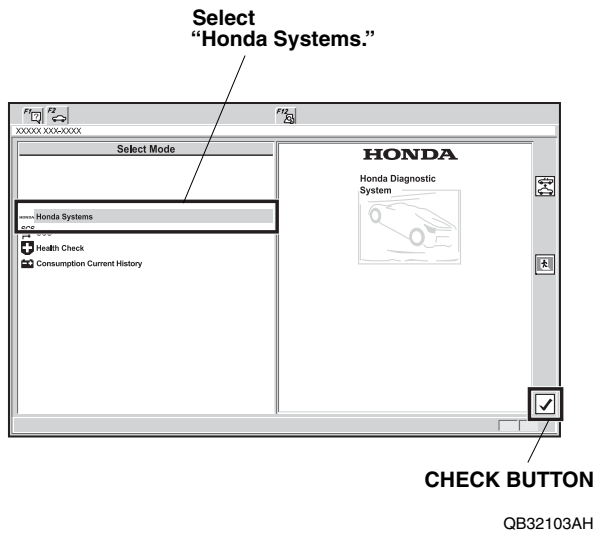

6. Select **R/C ENG STARTER** and click the check button.

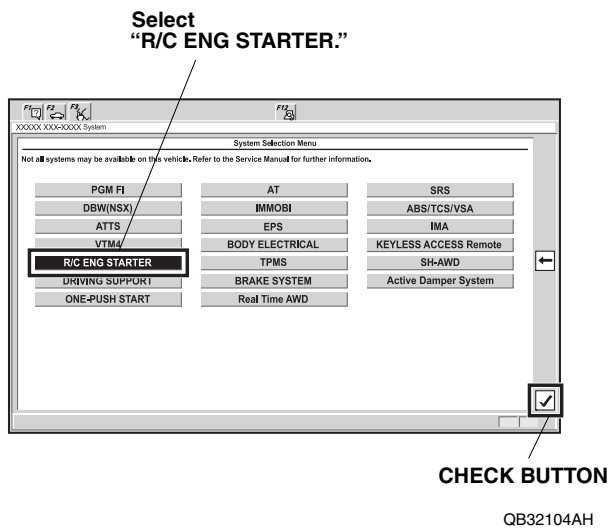

7. Select **REGISTER REMOTE CONTROL ENGINE STARTER UNIT**, then click the check button.

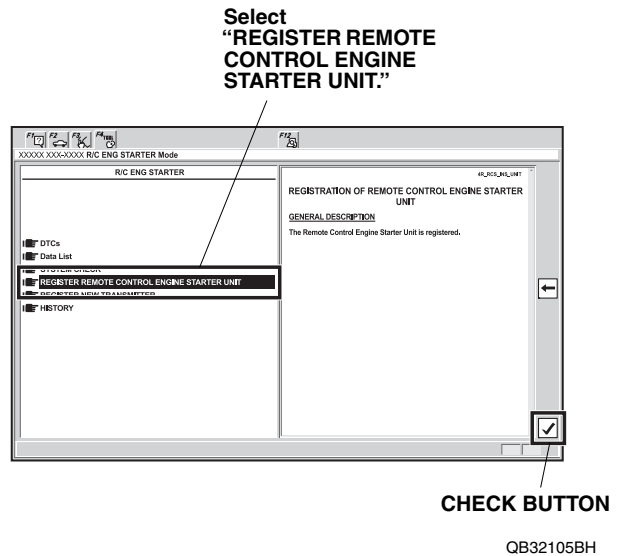

8. The following message will display: **Obtain PCM-code (IMMOBILIZER PCM CODE) from IN. This vehicle's VIN will be required to obtain the password. (USA)** Click the check button.

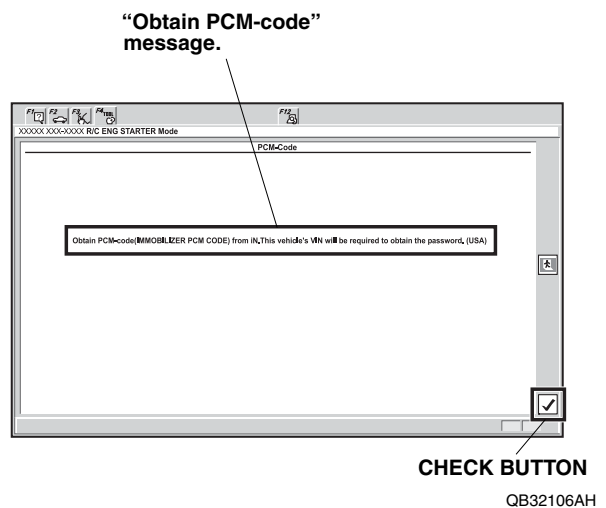

9. Input the PCM-code, then click the check button.
NOTE: To ensure security, the PCM-code (password) is changed everyday, so it is impossible to register the remote control engine starter if the dates of the PCM-code acquisition and registration are different. The date of the HDS/MVCI tester should also be the same.

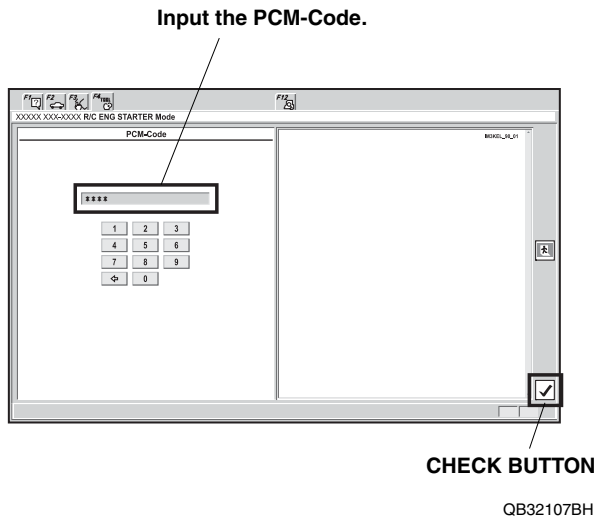

10. The following message will display: **The registration of the Remote Control Engine Starter Unit has been completed.** Turn the ignition switch off.

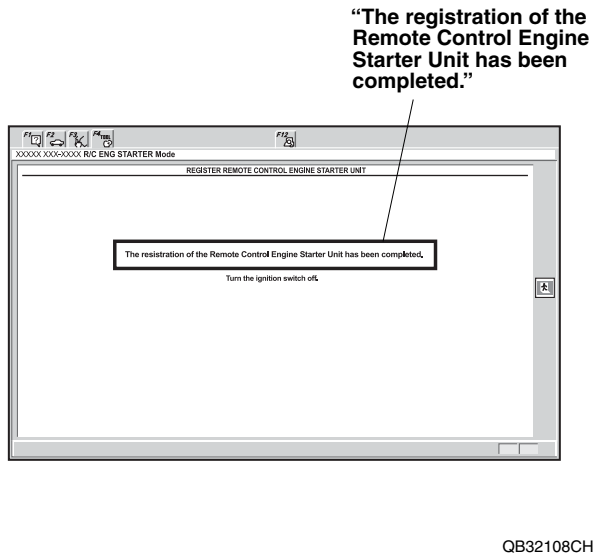

11. The following message will display: **Check that engine can be started by the Transmitter.** Click the check button.

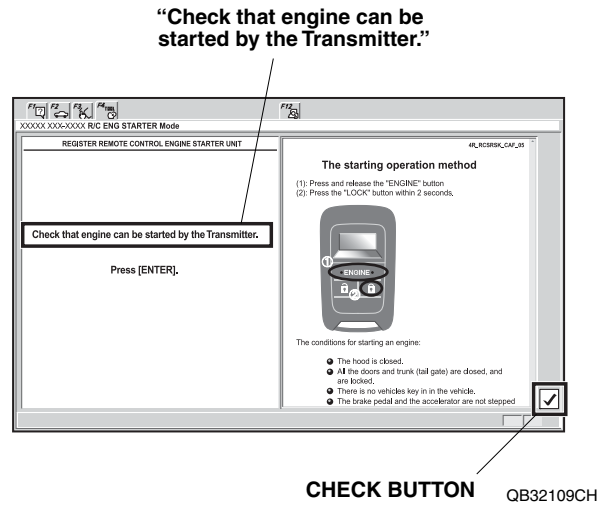

12. Perform the FUNCTION CHECK on page 26, then disconnect the HDS/MVCI.

FUNCTION CHECK

Operating Conditions

- The hood is closed
- The shift lever is in park
- Turn the ignition switch off and the key is outside the vehicle
- All doors and trunk lid closed and locked

Inspection

1. Press the engine/command button, and release on the transmitter, within 2 seconds, press the lock/start button on the transmitter.

The engine should start if all operating conditions are met.

Does the engine start?

Yes - Operation is normal.
No: <ul style="list-style-type: none">• Make sure all "Operating Conditions" are met.• Check the engine starter harness connections.• Connect the HDS/MVCI and check for an indicated failure. (Refer to the appropriate Service Manual for details.)

2. Press the engine/command button on the transmitter and release, within 2 seconds, press the unlock/stop button. The engine should stop.

Does the engine stop?

Yes - Operation is normal.
No - Check the engine starter harness connections.

3. After the engine has stopped, start the engine again, and check that the engine stops after each of the following conditions:

NOTE: After each test the ignition key must be cycled, or the driver's door must be opened and closed.

- Move the shift lever out of the P position.
- Unlock or open the doors or the trunk lid.
- Open the hood.
- Press on the brake pedal.
- Press the engine start/stop button.

Does the engine stop after each of these tests?

Yes - Operation is normal.
No - Check the engine starter harness connections.

4. Check that the power windows and the moonroof do not function, and the shift lever does not move to any position when the engine is started with the transmitter.
5. Check that the engine does not start under "Operating Conditions" with the key left inside the vehicle.
6. Start the engine again, press the engine/command button on the transmitter two times, and check the vehicle condition on the display.

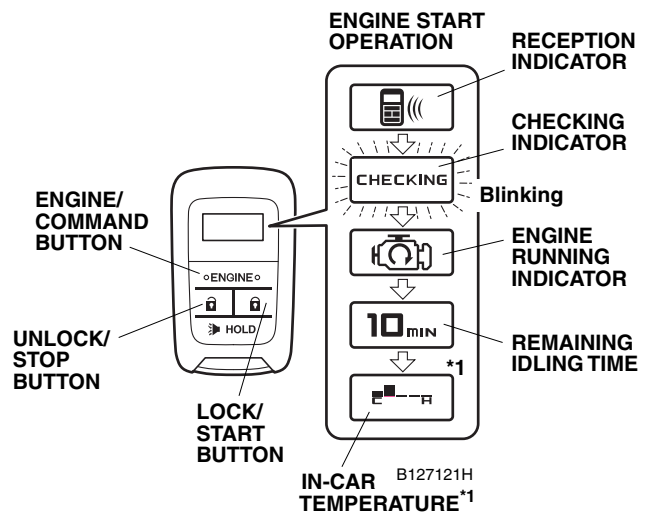

*1 Only on vehicles equipped with the automatic climate control. This indicator is displayed for some vehicles among them.

7. Check the operation of the transmitter when the vehicle is 120 m (400 ft.) away and in direct sight.
8. Press the unlock/stop button on the transmitter and verify that the doors unlock. Press the lock/start button, and verify that the doors lock.
9. Check that the engine can start by the vehicle key and that the wiper and the headlight can be operated normally.